



TECHBUD

YANMAR

C30R-3 C30R-3TV

CARRIER



C30R-3

C30R-3TV

Operating weight

2 650 kg

2 865 kg

Payload

2 500 kg

Engine

4TNV88C-KFW

WWW.YANMAR.pl

OPTIMIZATION OF YOUR PERFORMANCE IN NARROW AREAS





POWERFUL YANMAR ENGINE

The C30R-3 uses the newest version of the Yanmar TNV engines. It is a Yanmar 4-cylinder with direct injection and common rail system. This engine is also equipped with a cooled EGR and a DPF, which allow the machine to meet EN-Standards. Auto-deceleration and Eco-mode are available in standard.



HYDROSTATIC TRANSMISSION (HST)

The C30R-3 features a new variable speed, 2-pump, 2-motor, Hydrostatic System (HST) which enables a smooth control of the machine. The maneuverability of the machine is optimized in order to offer increased performance and productivity.



COMFORT

Upgraded operator station: new control panel, reversible seat, electronic instrumentation. The operator benefits from an ergonomic and comfortable working environment which reduces his fatigue.



BEST COMPONENTS

Developed in Japan with renowned components for top quality. Design and performance of the components made for long service life.



EASY OPERATION

Control levers ideally placed for exceptional movement precision. All the main commands are located on the joysticks for a maximum manoeuvrability and productivity.



COMPACTNESS

The C30R-3 has very compact dimensions which makes it the perfect tool for an efficient work in narrow urban jobsites.



HIGH PERFORMANCE

The C30R-3 presents a loading capacity of 2500 kg and a travelling speed up to 11 km/h. It can carry a large amount of material in a short time.



UNLOADING SYSTEM

The C30R-3 is available with two different unloading systems: a turning vessel (180°) and a three-way opening vessel. The shape of the vessel and the wide dumping angle ensure a fast unloading.

YOUR PERFECT PARTNER FOR NARROW JOBSITES



Yanmar has a long history of cultivating and incorporating new technology. Therefore, even in narrow and difficult urban construction sites, you can get the job done with overwhelming ease and comfort. Why don't you try a state-of-the-art carrier with high effectiveness, operability and flexibility?



Length: 3 280 mm/3 640 mm*



Width: 1 550 mm

*Standard vessel/Turning vessel.



COMPACTNESS

The C30R-3 is a very compact carrier for its class. It has a total width of 1.5 meter allowing this machine to be efficient even on very small jobsites. A total length of 3.28 meters (standard) and 3.64 meters (turning) makes it easy to turn in every condition, especially with the feature that this machine can spin-turn 360°. This configuration offers the following benefits:

- + Increased efficiency of the machine
- + Increased productivity for the operator

FLEXIBILITY

THE C30R-3 IS AVAILABLE IN 2 DIFFERENT CONFIGURATIONS:

- + The first version is the three-side flaps wagon type where the load is dumped in the rear. It has an incredible dumping angle of 58° and ground clearance of 455 mm. These two features insure that it is easy and fast to dump the load from the wagon. Furthermore, all sides can be opened separately.
- + The second version is with a swing wagon type. The wagon is mounted on a turning frame which can turn 180° (90° left, 90° right). This feature allows the C30R-3TV to dump the material by driving along a trench, and to get very close to the jobsite while maintaining a distance of security. This feature improves greatly safety and productivity.

Both versions are equipped with a mud guard to avoid any material from falling out of the wagon and damaging hydraulic components, or to ingress the operator area.



THREE-SIDE FLAPS WAGON WITH REAR DUMPING

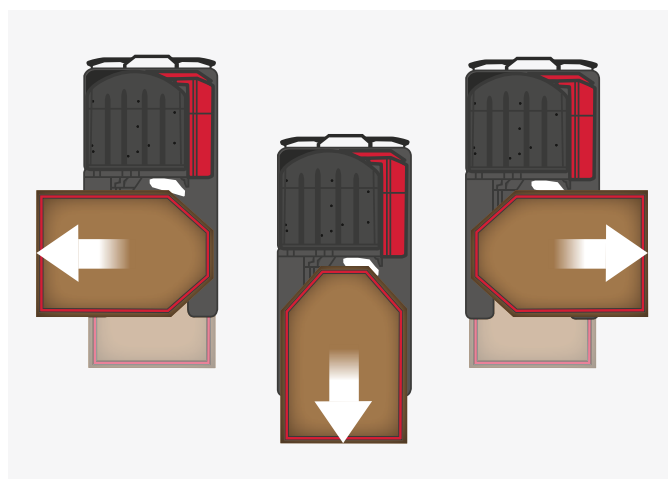

TURNING WAGON WITH 180° ROTATION

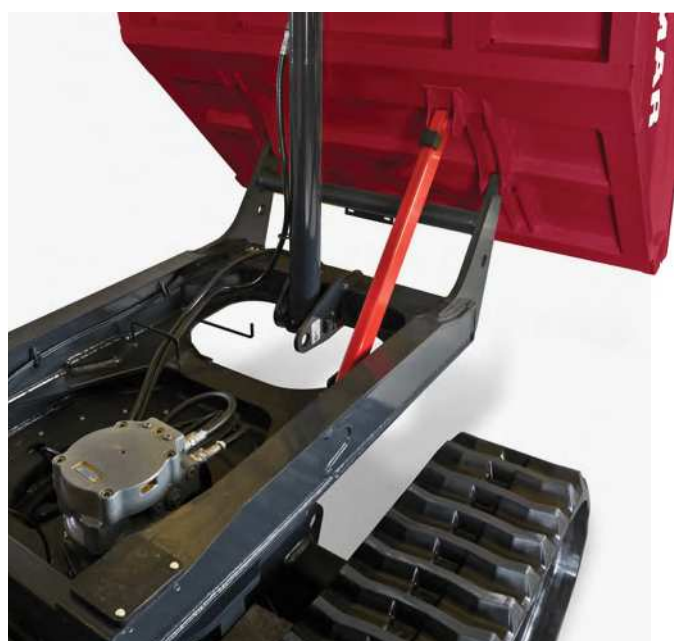

POWERLINE

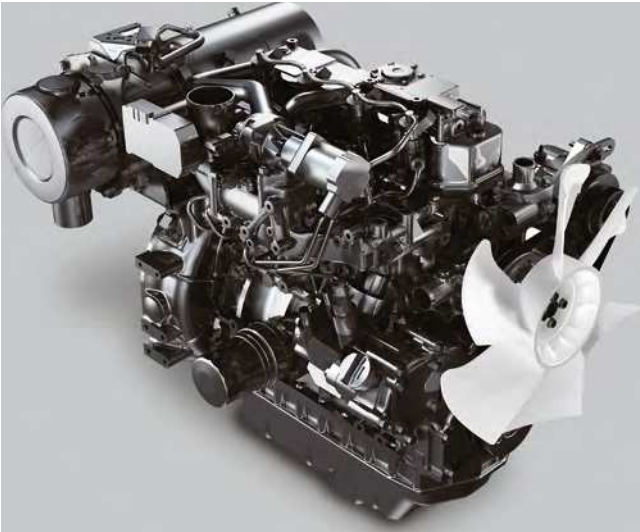

POWERFUL YANMAR ENGINE

The C30R-3 benefits from the most advanced technology of the leading manufacturer of industrial diesel engines. The 4TNV88C engine is equipped with direct injection to create clean burning power. It has fully-electronic control to provide the C30R-3 with total intelligent engine control. The engine is also equipped with a common rail system to allow fine-tuned electronic control of fuel injection.

Yanmar re-sized seriously the fuel tank by increasing the capacity by as much as 45% to 58 liters. This of course improves the autonomy by the same percentage reducing the downtime due to refuelling.

ELECTRICAL CONTROL SYSTEM EGR AND DPF

Yanmar customers with TNV engines are compliant with EN-Standards. This achieved through two features.

- + The first is the cooled EGR (Exhaust Gas Recirculation) which reduces drastically the nitrogen oxides (NOx).
- + The second is the DPF (Diesel Particulate Filter) to clean up exhaust emissions (PM). Yanmar has successfully developed an exclusive regeneration system in order to combat clogging and cleaning down-time.
- + An Auto-Deceleration system (in standard) further reduces fuel consumption by enabling the engine to drop back to idle if the operator doesn't touch the operating levers for 4 seconds.
- + An Eco-Mode (in standard) effectively controls the motor speed which is reduced by 330 rpm, thus allowing a very low fuel consumption.



UNIQUE TRANSMISSION CONCEPT

Yanmar has greatly improved the transmission system of the C30R-3. It is equipped with a new variable speed 2-pump, 2-motor Hydrostatic Transmission System (HST) which integrates an anti-stall feature.

Automatic hydraulic pressure adjustments allow the C30R to turn 360° smoothly without stalling the engine. The C30R-3 does a 360° spin-turn in as little as 9.5/18.0 seconds (empty vessel/with load 2 500 kg).

This feature offers to the customer an improved manoeuvrability, an increased driving comfort and increases the productivity.

2-PUMP / 2-MOTOR HYDROSTATIC TRANSMISSION SYSTEM (HST)

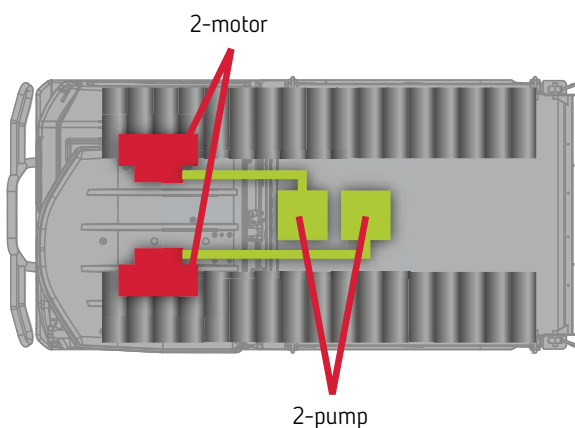

SPIN TURN BY REVERSE TURNING BOTH CRAWLERS

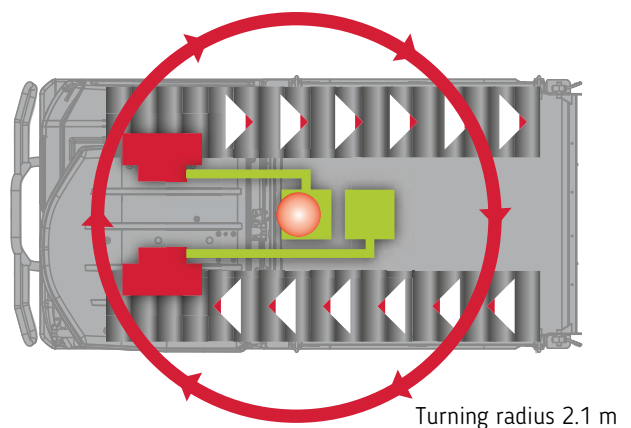

STABILITY

UNIQUE UNDERCARRIAGE

The C30R-3 benefits from a very robust undercarriage. To further improve the all-terrain capabilities, track rollers are mounted by pair on bogeys in order to better absorb obstacles. This feature improves the operator comfort and the service life of the undercarriage components.

- + The diameter of the sprocket and the length of the tracks have increased. This automatically improves the traction force and the stability of the C30R-3, and driving comfort and productivity.
- + The total mass of the C30R-3 is evenly distributed on the ground via 24 rollers. Fully loaded, the machine has a ground pressure as little as 0,57 kgf/cm². This improves the all-terrain capabilities drastically and the C30R-3 can work in the worst ground conditions.
- + The even distribution of the weight on the 24 rollers improves the service life of the tracks.



PERFORMANCE

The C30R-3 shows excellent performance on any jobsite. Whether in very narrow areas or on rough terrain, its high travelling speed and excellent vessel capacity (0,88 m³ with the standard vessel and 1,13 m³ with the turning vessel) enable to carry large amount of material fast and easily.

It can work on the most various ground conditions thanks to its robust and powerful undercarriage.

The C30R-3 benefits from a gradability of 30° and has a ground clearance of up to 280 mm (C30R-3TV): it can easily avoid obstacles and access isolated areas.



COMFORT



- + Yanmar has been paying a lot of attention to the operator station by modernizing the look and feel of the newest version of the C30R-3. The operator has a lot of space, even for the legs, in order to improve his comfort.
- + For the new version of the C30R-3, the instrumentation panel has been re-designed, all switches have been re-grouped close to the LED screen in order to improve the visibility for the operator, and make operation more intuitive and safer.

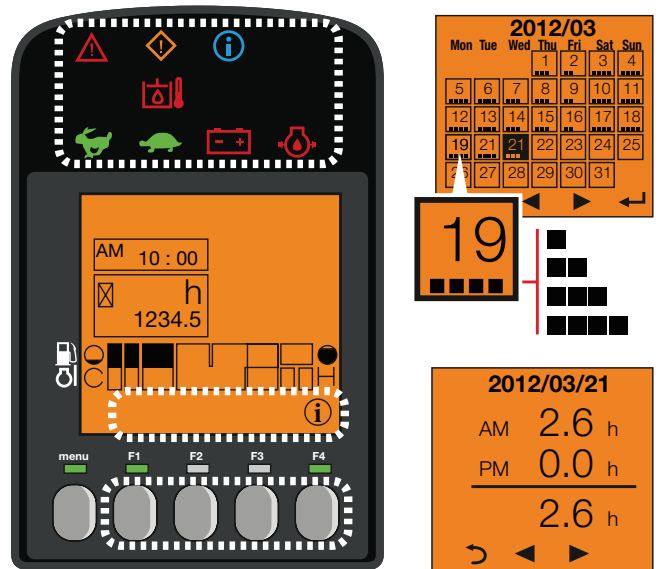

DIGITAL INTERFACE

The C30R-3 is equipped with a digital interface which informs the operator in real time about the status of his machine. Perfectly integrated into the right hand console, the 3.3" screen provides excellent visibility. The interface provides the customer with useful information through LED lamps, or indications about important elements like fuel consumption, fuel gauge, coolant temperature gauge, etc... The interface assists the customer for maintenance intervals and to program such interventions. It also works as a diagnostic tool in case of malfunction by sending an error code and an information icon on the display.

EASE OF USE

With the proportional control system, the machine only moves as far as the joystick lever is pushed, and stops when the lever is let go. Speed is controlled by moving the left joystick while vessel operation is controlled with the right joystick.

- + Forward and reverse travel, left and right turn, you can adjust speed and use
- + The travel automatic dual speed switch to change between low-speed and high-speed easily.
- + A lock / release switch prevents from inadvertent operation,
- + An accelerator pedal enables to make fine speed adjustments while operating the joystick.

RIGHT JOYSTICK: VESSEL OPERATION



SAFETY

For a maximum safety, the C30R-3 fitted with a ROPS/FOPS canopy and a seatbelt.

REVERSIBLE SEAT CONSOLE

The C30R-3 is equipped with a special feature, the operator seat and travel levers can turn 180°, allowing the operator to be always seated in the travel direction:

- + It improves drastically the safety
- + It improves the visibility of the operator
- + It reduces the risk of damages

PARKING BRAKE SWITCH

When you raise the lock levers the parking brake is automatically activated, preventing inadvertent travel or dumping, and keeping you safe. Simply push the parking switch to release the brake.



RELIABILITY

The structure of the undercarriage, as well as the steel covers provide an optimal protection and longer service life. Furthermore, a lot of care has been paid to the hose routing on the working equipment. These measures enhance the service life and reduce downtime of the machine.

All C30R-3 components were designed in order to make it reliable, durable and capable of performing demanding work.



MAINTENANCE

EASY ACCESS

Daily maintenance has to be performed easily. There is one easy way to open engine bonnet which gives an access to all major elements: air filter, compressor, battery, fuses and relays, fuel tank, hydraulic oil tank, engine oil dipstick...

LONG SERVICE INTERVALS

Yanmar carriers are designed for working and therefore we increase the service intervals to 500 hours. For our Diesel Particulate Filter, the Diesel Oxidation Catalyst is maintenance free, and the Soot Filter needs only to be cleaned every 3000 hours, which reduces downtime.



DIMENSIONS

C30R-3

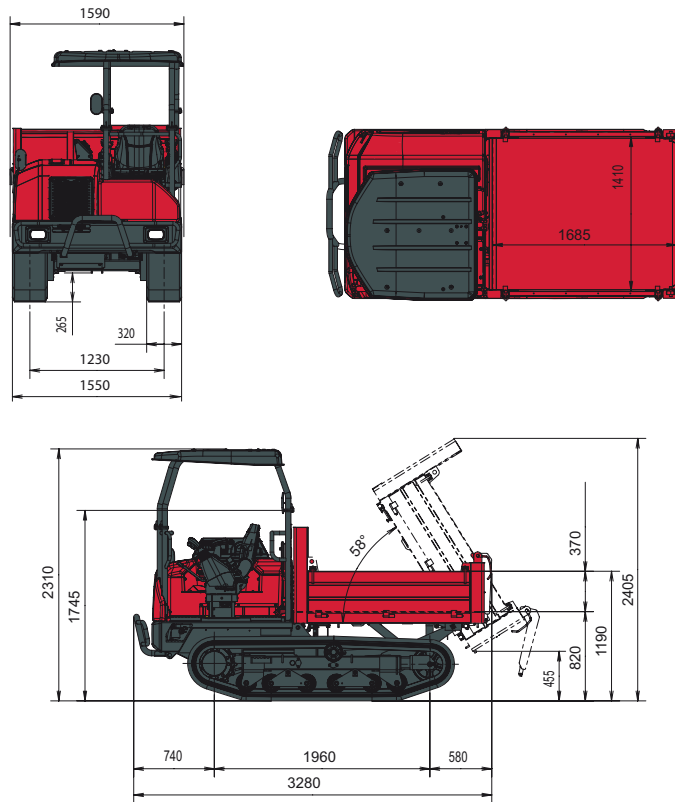

C30R-3TV

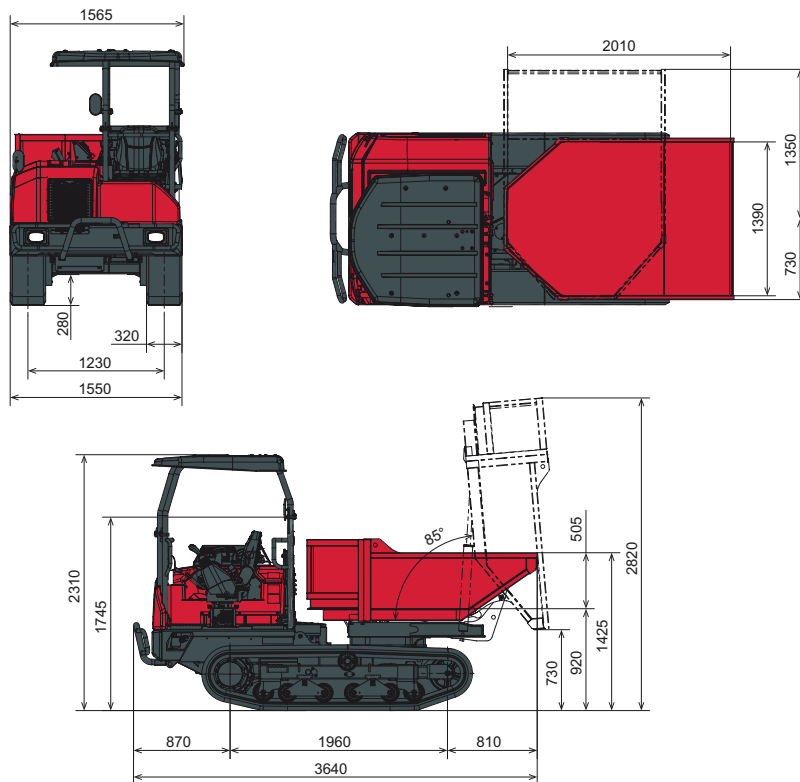

MAINTENANCE FREQUENCY

[Change engine oil and filter: 50 hours (1st) / 500 hours (2nd)] [Change fuel filter: 500 hours] [Change hydraulic oil filter: 1000 hours]
 [Change hydraulic oil return filter: 50 hours (1st) / 500 hours (2nd)] [Change cooling fluid: 2000 hours]

SPECIFICATIONS

[WEIGHT +/- 2% (EN STANDARDS)]

	C30R-3	C30R-3TV
Operating weight	2 650 kg	2 865 kg
Transport weight	2 575 kg	2 790 kg
Payload	2 500 kg	2 500 kg

[ENGINE]

Type	4TNV88C-KFW (Common Rail + DPF)
Regulation	Stage V
Fuel	Diesel
Gross power	34.3 kW (at 2 800 rpm)
Net power	32.5 kW (at 2 800 rpm)
Displacement	2 189 l
Maximum torque	134.5 – 146.2 N.m (at 1 820 rpm)
Cooling	Water cooling
Starter	12 V – 1.7 kW
Battery	12 V – 72 Ah
Alternator	12 V – 55 A

[HYDRAULIC SYSTEM]

Type	HST pump
Gear pump (charge pump)	33.3 l/min
Gear pump (implement pump)	22.7 l/min
2 piston pumps with variable flow	2 x 61.6 l/min
Max pressure	350 bar

[PERFORMANCE]

Max. travelling speed (low/high)	5.7/11 km/h
Traction force (1st speed)/ (2nd speed)	29 kN/auto kickdown, refer to 1st speed
Gradeability	30°
Noise level (2000/14/CE & 2005/88/CE)	Lwag = 98 dBA ; Lpag = 83 dBA

[DUMPING SYSTEM]

	C30R-3	C30R-3TV
Dumping angle	58°	85°
Vessel dimensions (LxWxH)	1 685x1 410x370 mm	2 010x1 390x505 mm
Dumping mechanism	3 sides	180° dumping
Dump vessel capacity (struck/heaped)	0.88/1.24 m ³	1.13/1.50 m ³
Dump clearance	455 mm	730 mm

[UNDERCARRIAGE]

	C30R-3	C30R-3TV
Track width	320 mm	320 mm
Ground clearance	265 mm	280 mm
Number of top rollers	1	1
Number of bottom rollers	6	6
Track tensioning system	Hydraulic adjuster	Hydraulic adjuster
Ground pressure (unloaded / loaded)	0.28/0.55 kgf/cm ²	0.30/0.57 kgf/cm ²

[CAPACITIES]

Hydraulic tank	28 l
Hydraulic circuit (including hydraulic tank) [C30R-3] / [C30R-3TV]	38 l/40 l
Coolant	5.7 l
Engine oil	7.4 l
Fuel tank	58 l

MAINTENANCE FREQUENCY :

[Change engine oil and filter : 500 h] [Change fuel filter : 250 h] [Change hydraulic oil filter : 500 h] [Change hydraulic oil : 500 h]
[Change hydraulic oil return filter : 500 h] [Change cooling fluid : 2000 h]



YANMAR



GB_C30R-3_0622

AUTORYZOWANY PARTNER:

TECHBUD

SILNIKI • MASZINY BUDOWLANE • DROGOWE • AGREGATY

Techbud Sp. z o.o.
ul. Gorzowska 12
65-127 Zielona Góra

tel. +48 68 470 72 50
fax +48 68 470 72 51
www.techbud.eu
techbud@techbud.eu

**BUILDING
WITH YOU**